

# How to Design a Vacuum Cleaner Motor Drive Inverter Using EPC9176 Evaluation Boards



## Motivation

Due to the ever-increasing demand for highly efficient and compact motor drive applications, EPC has designed the **EPC9176** board that employs eGaN IC that serves to achieve maximum performance for vacuum cleaner inverters. The EPC9176 uses three **EPC23102** eGaN ICs. Such a board is a three-phase inverter capable of delivering 13 A<sub>RMS</sub> without a heatsink and 18 A<sub>RMS</sub> with a heatsink keeping the temperature rise of the IC below 50 °C. EPC9176 board supports PWM switching frequencies up to 250 kHz.

## System overview

The inverter board includes all the function circuits required to support a complete inverter for vacuum cleaner motor drive as described in the following:

- Three-phase inverter based on six **EPC23102** eGaN ICs;
- DC link capacitors;
- Regulated auxiliary power supplies;
- Voltage, current, and temperature sensors with conditioning circuits;
- Protection functions

The pictures of the inverter board and are displayed in Figure 1.

A controller connector (J60) interfaces the EPC9176 signals with an external digital microcontroller unit.

The switching cells are arranged with a symmetrical layout. The phase output current is measured through shunt resistors. There are sensing resistors in phase with the motor connections for each phase. Furthermore, a compatible motor shaft encoder or hall effect sensor can be connected to the EPC9176 motor control drive inverter through the connector J80 and the output filtered signals are available to the microcontroller on the connector J60. [1]

A built-in overcurrent detection circuit is triggered if an overcurrent (OC) occurs; the OC signal is sent through the J60 connector to the microcontroller.

The DC-link capacitors balance the fluctuating instantaneous power exchange between the supply and the inverter to stabilize the ripple caused by the inverter high-frequency power switching circuits. High switching frequency allows reducing the required capacitance value. For this reason, the DC-link is realized by ceramic and tantalum capacitors and the user can customize the EPC9176 to find the optimum filtering in both high and low switching frequency operative conditions.

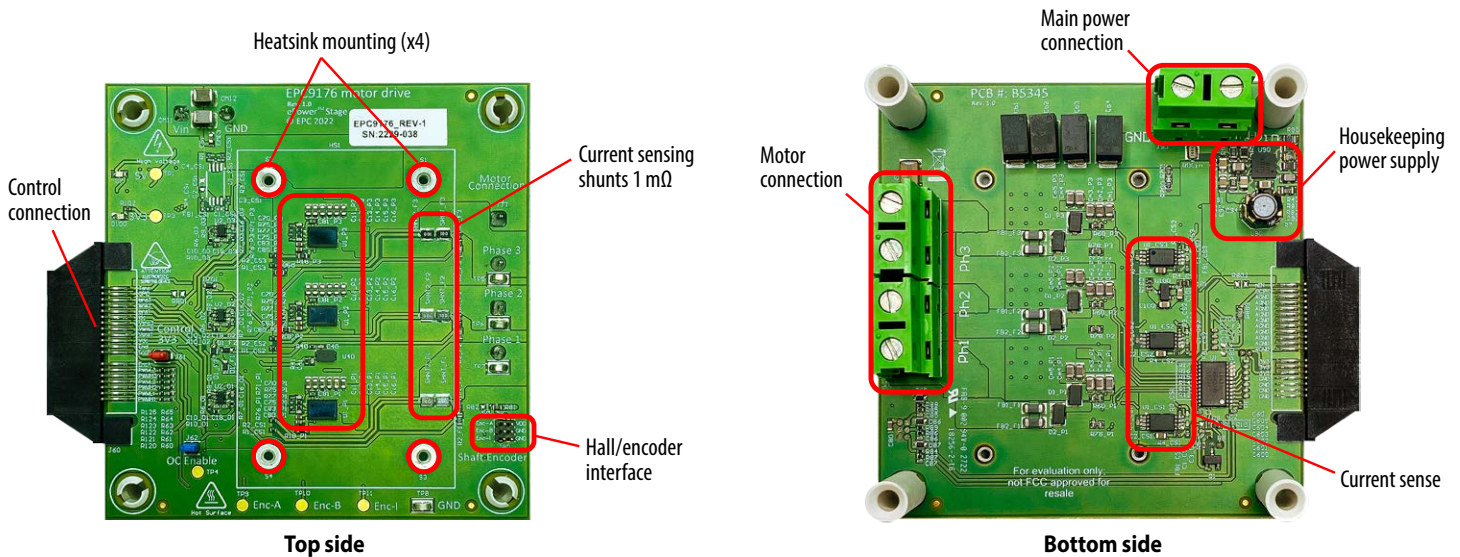

Figure 1. Photo overview of the EPC9176 board highlighting the main sections

The EPC9176 is equipped with a dedicated heat sink for natural convection cooling shown in Figure 2.

The heat sink is grounded and is mounted on top of a thin layer of insulation material to prevent the short-circuit with other components that have exposed pins conductors. The thermal interface material (TIM) is placed above the eGaN ICs to improve the interface thermal conductance between the die and the attached heatsink. The TIM used for this board is **t-Global** P/N: TG-A6200 x 0.5 mm with a conductivity of 6.2 W/m·K.

**eGaN IC selection for motor drive inverter**

EPC9176 is a three-phase inverter made of three EPC23102 eGaN ICs.

Gallium nitride device technology has an exceptional high electron mobility and low-temperature coefficient. The EPC23102 eGaN IC has a typical Drain-Source ON Resistance  $R_{DS(on)}$  of 5.2 mΩ (@25°C).

In addition, the lateral structure of the eGaN device and the absence of an intrinsic body diode provide an exceptional low gate charge  $Q_G$  and a zero reverse recovery charge  $Q_{RR}$  when operated in reverse conduction. When compared to MOSFETs with similar  $R_{DS(on)}$ , eGaN FETs have five times smaller switching losses, so the inverter can be operated at higher PWM frequency and with shorter dead time.

The package of the eGaN ICs allows near zero common source parasitic inductance having high-side device and low-side device on the same chip and the power loop parasitic inductances by soldering the chip directly onto the printed circuit board. The small footprint allows inserting three EPC23102 in the board in a relatively small area providing high power density. The footprint of the EPC23102 is shown in Figure 3.

**Design Overview**

The eGaN ICs of the power stage have a maximum voltage of  $V_{DS} = 100$  V. The  $dv/dt$  is optimized for motor drive applications to be less than 10 V/ns.

The current is sensed in both directions per motor phase by using phase shunt resistors. The shunt value is 1.0 mΩ and the voltage drop across the shunt is amplified with a gain of 50 V/V, and an offset of 1.65 V is added. The amplifiers bandwidth is 400 kHz, adequate for accurate motor control operation at high switching frequency operation. The amplified signals across the phase shunt resistors are used to detect the overcurrent of each leg for prompt activation of the analog circuit protections. An active-low over-current signal (OCPn) is also sent to the microcontroller connector J60 for proper fault handling.

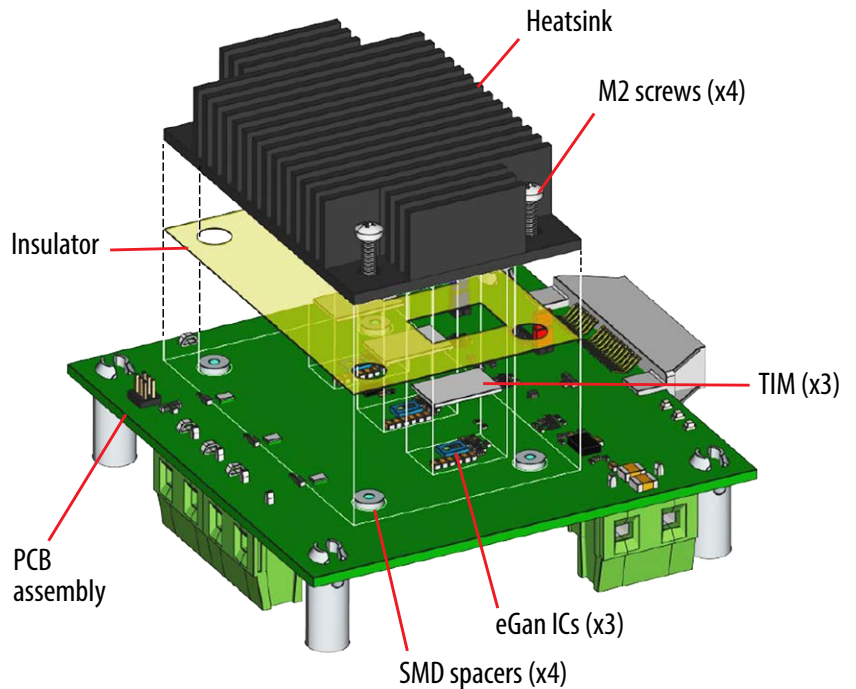

Figure 2. Details for attaching a heatsink to the board.

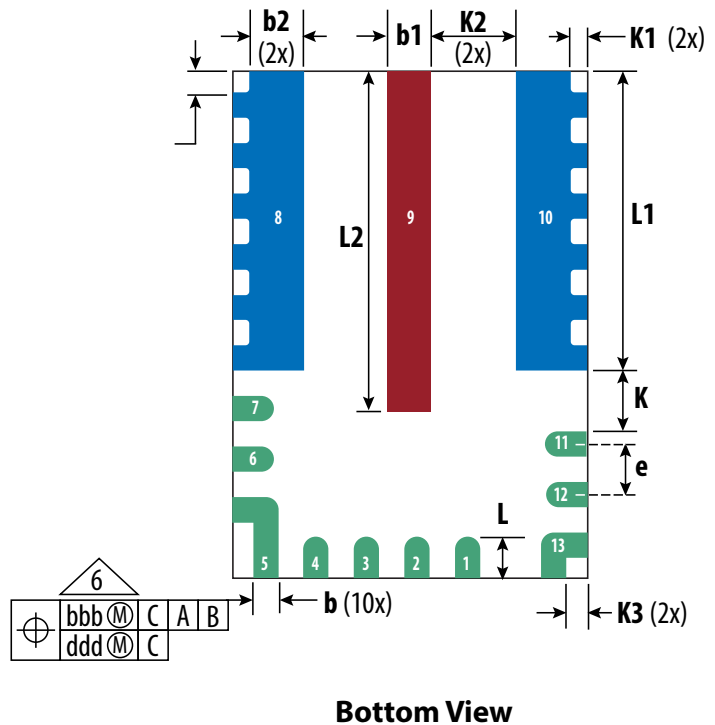

Figure 3. EPC23102 eGaN package footprint bottom view

A snapshot of the oscilloscope showing overcurrent action is presented in figure 4. The green trace is the phase current; the magenta trace is the signal at the output of the current amplifier. The overcurrent circuit is unidirectional and is triggered when the current exceeds -32 A.

The overcurrent (OC) detection circuit is triggered if a negative current greater than 32 A is measured in any of the three phases. In this condition, the active-low OCPn signal will remain low for a short time determined by a 10 ms RC time constant. The OCPn signal is sent through the connector J60 to a dedicated interrupt pin of the microcontroller. The microcontroller reaction can be programmed accordingly, with a fast reaction time.

DC supply voltage and each phase voltage are measured using a resistor divider network that yields a total gain of 29.2 mV/V.

The temperature sensor (U40 – AD590) on the inverter board feeds back a voltage on the J60 connector that is proportional to the temperature using the following equation

$$T = \left( \frac{V \cdot 1000}{7.87} \right) - 273.15 \text{ [}^\circ\text{C]} \quad (1)$$

The temperature sensor has been characterized with the use of an infrared camera measuring the temperature at the top of the EPC23102 case. The relationship is shown in Figure 5.

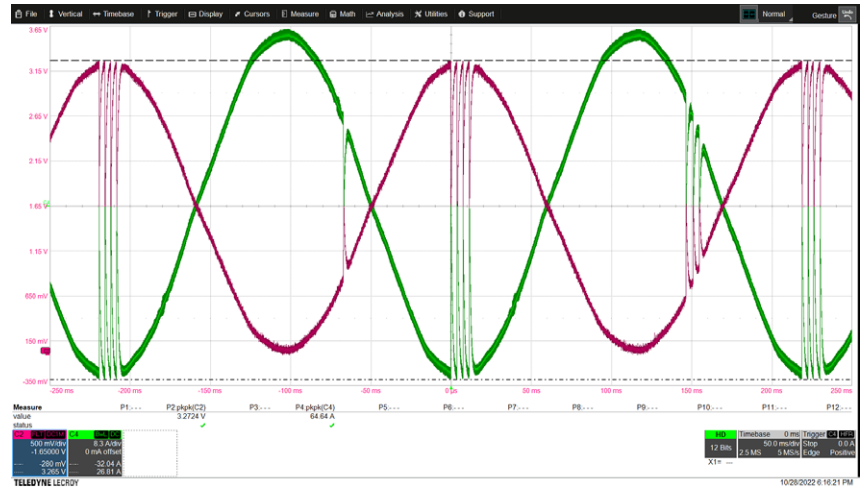

Figure 4. Phase current and current sense signals. Note that the voltage threshold is positive, but the kelvin connections on the shunt resistor make the overcurrent circuit active at negative current values. As measured by the cursors, the overcurrent threshold is set at -32 A

### Temperature Sensor Characterization

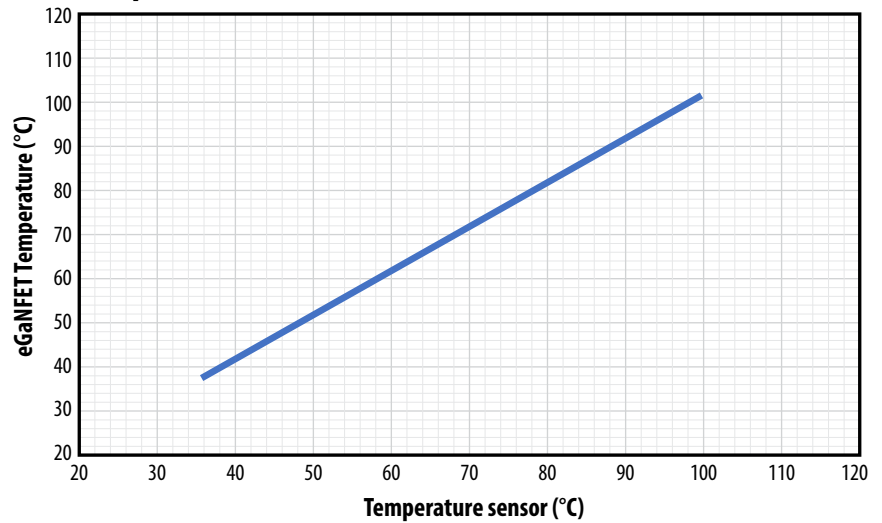

Figure 5. eGaN IC case temperature vs. temperature sensor placed on bottom of the PCB. Operation under natural convection without heatsink.



## Experimental Validation *(continued)*

Figure 7, shows the phase current waveforms of the motor running at 50 krpm.

The input voltage ripple in an inverter is inversely proportional to the input capacitance and to the PWM frequency. Given a maximum input voltage requirement and the PWM frequency it is possible to determine the minimum input capacitance needed. However, at low PWM frequencies (i.e. 20 kHz) it is required to use electrolytic or tantalum capacitors. In the case of EPC9176, tantalum capacitors were used. If the PWM frequency is increased, the required input capacitance allows the usage of ceramic capacitors.

At 80 kHz PWM frequency the input voltage and current ripple decrease, allowing the designer to remove the tantalum capacitors and use only ceramic capacitors.

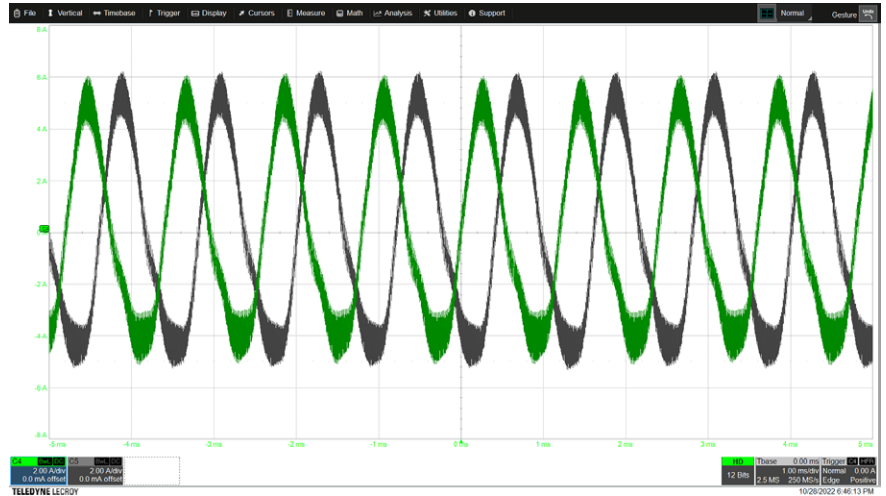

Figure 7. Measured motor phase currents powering a vacuum cleaner motor operating at 50 krpm

## Conclusion

The EPC9176 is a 48 V input, 400 W output, equipped with the EPC23102 eGaN ICs, designed for vacuum cleaner applications. It integrates all the necessary circuits to operate a 3-phase BLDC motor with high performance. Thanks to the high power density and the high electrical conductivity of eGaN, the board delivers up to 18 A<sub>RMS</sub> on each leg and supports PWM switching frequencies up to 250 kHz under natural convection passive heatsink and by keeping the temperature rise below 50°C. Increasing performance of the motor-drive system in terms of quality of the current output waveforms, lesser torque oscillations, and total system efficiency are achieved.

## References

- [1] EFFICIENT POWER CONVERSION, 2021. [Online]. Available: [https://epc-co.com/epc/Portals/0/epc/documents/schematics/EPC9173\\_schematic.pdf](https://epc-co.com/epc/Portals/0/epc/documents/schematics/EPC9173_schematic.pdf)
- [2] EFFICIENT POWER CONVERSION, "Demonstration Board EPC9176 Quick Start Guide," 2022. [Online]. Available: [https://epc-co.com/epc/Portals/0/epc/documents/guides/EPC9176\\_qsg.pdf](https://epc-co.com/epc/Portals/0/epc/documents/guides/EPC9176_qsg.pdf)
- [3] EFFICIENT POWER CONVERSION, "EPC23102 ePower™ Stage IC" 2022. [Online]. Available: [https://epc-co.com/epc/Portals/0/epc/documents/datasheets/EPC23102\\_preliminary.pdf](https://epc-co.com/epc/Portals/0/epc/documents/datasheets/EPC23102_preliminary.pdf)
- [4] S. Musumeci, F. Mandrile, V. Barba, M. Palma, "Low-Voltage GaN FETs in Motor Control Application; Issues and Advantages: A Review," *Energies*, 2021.
- [5] F. Mandrile, S. Musumeci, M. Palma, "Dead Time Management in GaN Based Three-Phase Motor Drives," *IEEE EPE*, 2021.

### For More Information

Please contact [info@epc-co.com](mailto:info@epc-co.com)  
or your local sales representative

Visit our website: [epc-co.com](http://epc-co.com)

Sign-up to receive EPC updates at  
[bit.ly/EPcupdates](http://bit.ly/EPcupdates)



eGaN is a registered trademark of Efficient Power Conversion Corporation

